

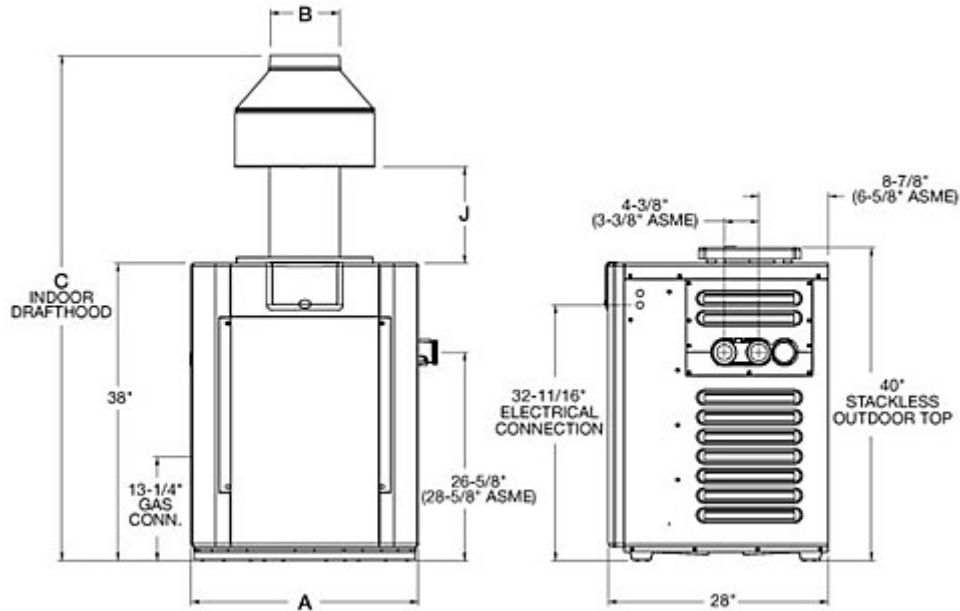

## Digital and Millivolt Technical Data



Heater Model	BTUH Input (000)	A	B	C	J	Gas Conn	Water Conn	Ship Weight (lbs)		
								ASME	Polymer	Indoor Top
R-206	199.5	20	6	61-5/8	11-7/8	3/4	2	206	187	12
R-266	266.0	23	7	62	11	3/4	2	229	210	15
R-336	332.5	26	8	63	10-5/8	3/4	2	249	230	17
R-406	399.0	29	9	64-1/2	12-5/16	3/4	2	268	249	20

Designation for a Digital heater using propane gas is "EP";

a Digital heater using natural gas is "EN".

Designation for a Millivolt heater using propane gas is "MP";

a Millivolt heater using natural gas is "MN".

Prefix "P" is for plastic (polymer) headers; "C" is for cast iron (ASME) headers.

Suffix "X" is for cupro-nickel tubing; "C" is for copper tubing

Example: **P-R406A-EN-X** = Plastic headers, 406 model size, digital, natural gas, cupro-nickel

Reduce input 4% for each 1000 feet above sea level when installed above 2000 feet elevation.

Manufactured under Patent No. 3,623,458.

Plastic (polymer) headers cannot be used for installations requiring ASME certification.

### How to Pick the Right Size Heater

Proper heater size is based on the time required to heat the pool or spa. If water is heated for each intended use, energy-saving rapid heating may be appropriate. If water is gradually heated to the desired temperature and then maintained at that temperature, a smaller heater may be acceptable. To determine proper heater size, use the following formula.

$$\frac{\text{Desired water temperature (°F)} - \text{Average air temperature (°F)}}{\text{Required temperature rise (°F)}} \div \text{Required time to heat pool/spa to desired water temp. (hours)} = \text{Required temperature rise per hour (°F)}$$

Model	Pool Size - Square Feet						
	300	400	500	600	700	800	1000
	Desired temperature rise in °F per hour						
<b>206</b>	1-1/2	1-1/4	1	1	3/4	-	-
<b>266</b>	2	1-3/4	1-1/2	1-1/2	1	3/4	
<b>336</b>	3	2	2	1-3/4	1-1/4	1	3/4
<b>406</b>	3-1/2	2-3/4	2-1/2	2	1-1/2	1-1/4	1

Model	Spa Size - Gallons						
	300	400	500	600	700	800	1000
	Desired temperature rise in °F per hour						
<b>206</b>	65	49	39	33	28	25	20
<b>266</b>	87	65	52	44	37	33	26
<b>336</b>	109	82	65	55	47	41	33
<b>406</b>	131	98	79	65	56	49	39